

**COPES-VULCAN**  
AN SPX BRAND

# VO-II & VO-76

## Variable Orifice Desuperheater



**SPX**<sup>®</sup>

## Description and Principle of Operation

The Variable Orifice Desuperheater consists of a body which houses the desuperheater internals. The body incorporates a screwed-in seat over which a cage is located in such a manner that a coolant annulus is created around the seat. The coolant enters this annulus by means of a branch on the desuperheater body. The plug is free floating but incorporates a spring-loaded button which provides stability to the plug under light load conditions. Incorporated in the top of the cage is a plug stop to limit the amount of travel of the plug.

In service, incoming vapor acts on the underside of the plug, which is weighted in such a manner that a certain amount of the energy in the vapor is used to lift the plug. As more vapor flows through the desuperheater, the higher the plug is lifted, thus creating a variable orifice for the vapor flow. The energy used in lifting the plug creates a pressure drop across the seat which is quite constant regardless of the vapor flow. This pressure drop creates a relatively high velocity across the seat area, and it is at this point of low pressure constant velocity that the coolant is admitted into the vapor flow.

Coolant enters the annulus under the dictates of a control valve responsive to a temperature controller sensing the downstream vapor temperature. The coolant is admitted into the vapor flow through a peripheral gap between the underside of the cage and the top of the seat. Coolant is admitted all around the seat, thus ensuring that unequal cooling does not occur.

The coolant is picked up by the vapor flow as it discharges from the seat, and the low pressure zone that exists at this point is instrumental in atomizing the coolant into fine particles. In the turbulence which ensues as a result of the change in direction and velocity of the vapor, intimate mixing of the vapor and coolant takes place. Above the plug, as the vapor attempts to return to laminar flow, a vortex is created and any particles of coolant not completely absorbed by the vapor are drawn into this vortex where they suffer a further pressure reduction which again speeds up the atomizing process.

As virtually all of the desuperheating occurs within the desuperheater body itself, and as no coolant impinges on either the desuperheater or associated piping, no protective thermal liners are required.

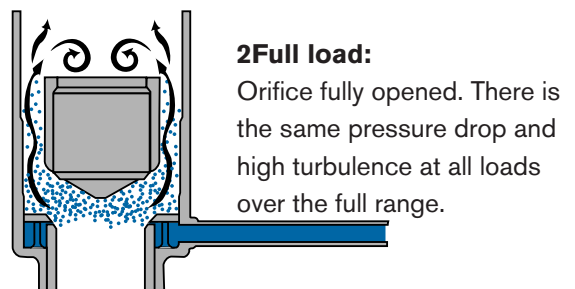
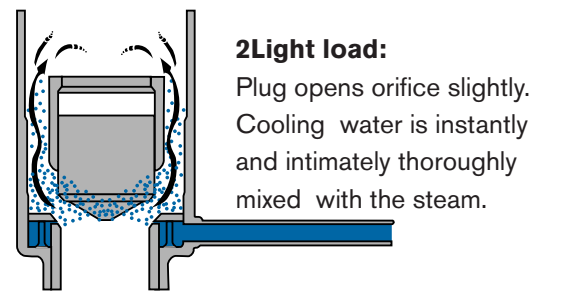
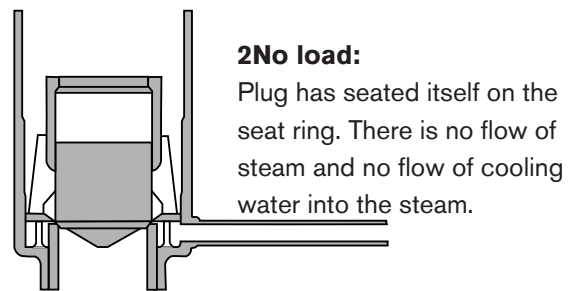
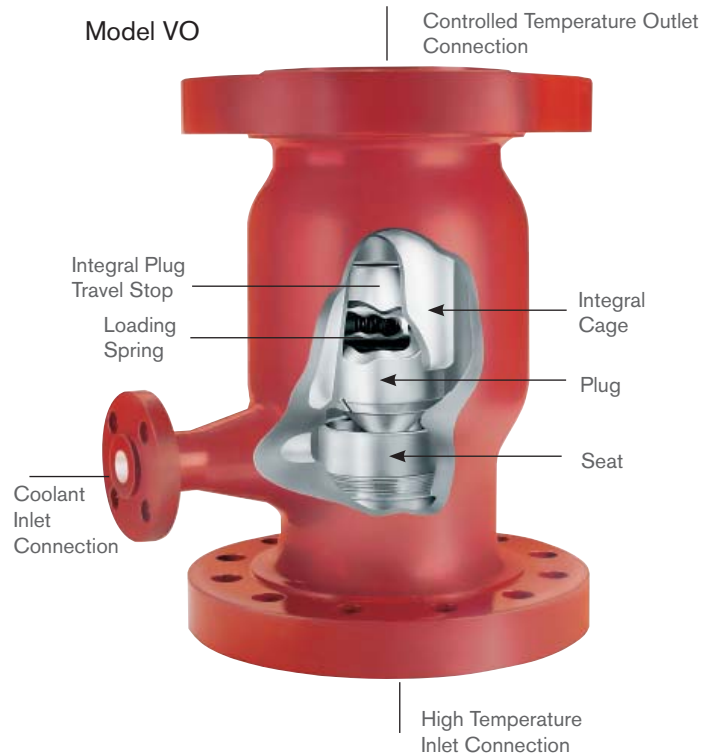

## Variable Orifice Desuperheater

Copes-Vulcan's VO Variable Orifice Desuperheater is recognized industry wide as the most versatile desuperheater available. It is easily capable of meeting the most demanding needs for desuperheating in both the power and process industries.

The VO offers extremely fine control and exceptional turndown that is limited only by the rangeability of the coolant control valve itself.

With excellent mixing of vapor and coolant, control is possible throughout the entire operating range to within  $3 \pm 5^\circ \text{F}$  ( $\pm 2.5^\circ \text{C}$ ) of the set point which can be as close as  $10^\circ \text{F}$  ( $5^\circ \text{C}$ ) above saturation.

The coolant pressure which is required at the inlet to the VO need only be 5 psi (35 kPa) above the pressure of the vapor being desuperheated.

Because virtually all of the desuperheating occurs within the VO body itself, the temperature sensing element can be as close as 14—20' (4—6m) from the desuperheater outlet.

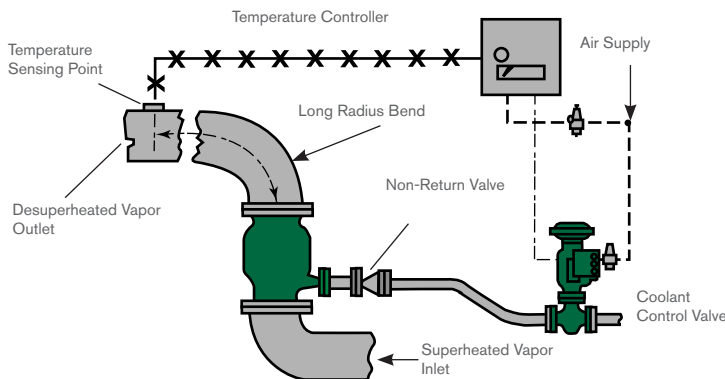

### Installation

The desuperheater is designed for installation in a vertical run of pipe with flow upwards. There are no requirements for straight pipe upstream or downstream of the unit, however, if a bend is located immediately at the outlet, it should be a long radius elbow.

### Model VO-II Design

The basic design of the pressure retaining part of the VO-II is in accordance with ANSI B16.5 (B.S.1560).

### Sizes

The VO-II is currently available in sizes 3" (80mm) through 20" (500mm).

### Materials of Construction

Carbon steel ASTM A216-WCB

Low alloy steel ASTM A217-WC6

Other castable materials available on request.

### Pressure Ratings

VO-II desuperheaters are available in ANSI pressure classes 150, 300, 600 and 900. For additional sizes, pressure classes, and configurations, refer to Model VO-76.

### End Connections

VO-II desuperheaters are normally supplied with flanged connections to ANSI (BS 1560) DIN (BS 4540) or BS10. For additional sizes, end connections, and configurations, refer to Model VO-76.

### Sizing/Selection

The VO-II and all Copes-Vulcan desuperheaters can be sized by Copes-Vulcan or an authorized Sales Representative using the SmartSize for Steam Conditioning Equipment computer sizing program to assure correct application.

Typical information required to size:

- Process steam flow rates
- Process steam pressure
- Process steam temperature (superheated)
- Desired process steam temperature(desuperheated)
- Available cooling water pressure
- Available cooling water temperature
- Process steam line size and schedule

## VO-II Dimensions

150/900 Class Rating

| Unit Size | Norm. Bore |           | 150/300 Rating |              |             | 600 Rating    |              |              | 900 Rating    |              |              |
|-----------|------------|-----------|----------------|--------------|-------------|---------------|--------------|--------------|---------------|--------------|--------------|
|           | A          | B         | C              | D            | E           | C             | D            | E            | C             | D            | E            |
| 3<br>80   | 3<br>80    | 1<br>25   | 13<br>330      | 7<br>178     | 5<br>127    | 13.75<br>349  | 7.25<br>184  | 5.38<br>137  | 14.25<br>362  | 7.63<br>194  | 5.63<br>143  |
| 4<br>100  | 4<br>100   | 1<br>25   | 14<br>356      | 7.5<br>191   | 5<br>127    | 15<br>381     | 7.75<br>197  | 5.5<br>140   | 15.5<br>394   | 8.13<br>206  | 5.75<br>146  |
| 6<br>150  | 6<br>150   | 1<br>25   | 18<br>457      | 9.63<br>244  | 6<br>152    | 19.25<br>489  | 9.88<br>251  | 6.63<br>168  | 20<br>508     | 10.25<br>260 | 7<br>178     |
| 8<br>200  | 8<br>200   | 1<br>25   | 22<br>559      | 10.75<br>273 | 6.5<br>165  | 23.75<br>603  | 11<br>279    | 7.38<br>187  | 24.25<br>616  | 11.38<br>289 | 7.63<br>194  |
| 10<br>250 | 10<br>250  | 1.5<br>40 | 27.75<br>705   | 12.75<br>324 | 7.75<br>197 | 29.5<br>749   | 13<br>330    | 8.63<br>219  | 30<br>762     | 13.38<br>340 | 8.88<br>225  |
| 12<br>300 | 12<br>300  | 1.5<br>40 | 34<br>864      | 15<br>381    | 8.75<br>222 | 35.75<br>908  | 15.25<br>387 | 9.63<br>244  | 36.75<br>933  | 15.63<br>397 | 10.13<br>257 |
| 14<br>350 | 14<br>350  | 1.5<br>40 | 39.5<br>1003   | 17<br>432    | 9<br>229    | 41.25<br>1048 | 17.25<br>438 | 9.88<br>251  | 42.5<br>1079  | 17.63<br>448 | 10.5<br>267  |
| 16<br>400 | 16<br>400  | 1.5<br>40 | 43<br>1092     | 20<br>508    | 10<br>254   | 44.5<br>1130  | 20.25<br>514 | 10.75<br>273 | 46<br>1168    | 20.63<br>524 | 11.5<br>292  |
| 18<br>450 | 18<br>450  | 1.5<br>40 | 50<br>1422     | 21<br>533    | 11<br>279   | 55.25<br>1480 | 21.25<br>540 | 12.13<br>303 | 59.75<br>1518 | 21.63<br>549 | 12.88<br>327 |
| 20<br>500 | 20<br>500  | 2<br>50   | —              | —            | —           | —             | —            | —            | —             | —            | —            |

Inch

Millimeter

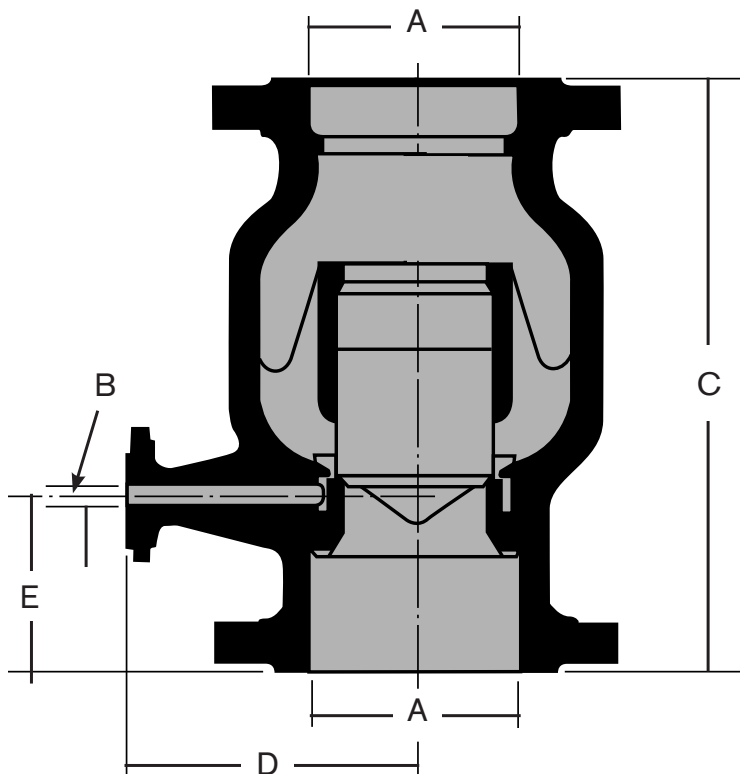

## Model VO-76

While virtually identical in operation and performance to the VO-II, the VO-76 is offered by Copes-Vulcan as an alternate when existing piping requires a custom fit, where pressure ratings exceed class 900, or where size requirements exceed those offered in the VO-II.

As “Arrangement #1,” the VO-76 housing is supplied as a cast unit with integral inlet flange and butt weld outlet. “Arrangement #2” welds a reducer to the above description. The standard reducer results in a butt weld outlet the same nominal size as the flanged inlet, but non-standard sizes are also available.

As “Arrangement #3,” a weld neck flange is added to the combination of housing and reducer. Again, the standard arrangement has the same size inlet and outlet flanges.

By using various sized reducers/expanders and/or flanges, an almost endless variation of dimensions and end connections can be achieved.

The VO-76 is also available with a housing fabricated from forged and wrought piping components when technical specifications and/or N.D.T. requirements preclude the use of castings. Again, reducers and flanges can be added as required, but unlike the cast VO-76, this applies to both inlet and outlet on the fabricated version of the VO-76.



# VO-76 Dimensions

ANSI Pressure Classes 150-1500

| Size     | ANSI Class | A<br>Housing        | B<br>Housing w/<br>Reducer | C<br>Housing w/<br>Reducer &<br>Outlet Flange | D<br>Housing &<br>Reducer<br>I.D. | E<br>Coolant<br>Flange<br>Size | F &<br>G |
|----------|------------|---------------------|----------------------------|---|-----------------------------------|--------------------------------|----------|
| 2<br>50  | 150        | <u>10.75</u><br>273 | <u>15.75</u><br>400        | <u>18.25</u><br>464                           | 5<br>127                          | .75<br>19                      |          |
|          | 300        | <u>10.75</u><br>273 | <u>15.75</u><br>400        | <u>18.5</u><br>470                            |                                   |                                |          |
|          | 400        | <u>10.75</u><br>273 | <u>15.75</u><br>400        | <u>18.88</u><br>479                           |                                   |                                |          |
|          | 600        | <u>10.75</u><br>273 | <u>15.75</u><br>400        | <u>18.88</u><br>479                           |                                   |                                |          |
|          | 900        | <u>11.5</u><br>292  | <u>16.5</u><br>419         | <u>20.75</u><br>527                           |                                   |                                |          |
|          | 1500       | <u>11.5</u><br>292  | <u>16.5</u><br>419         | <u>20.75</u><br>527                           |                                   |                                |          |
| 3<br>75  | 150        | <u>10.75</u><br>273 | <u>16.25</u><br>413        | <u>19</u><br>483                              | 6<br>152                          | .75<br>19                      |          |
|          | 300        | <u>10.75</u><br>273 | <u>16.25</u><br>413        | <u>19.38</u><br>492                           |                                   |                                |          |
|          | 400        | <u>10.75</u><br>273 | <u>16.25</u><br>413        | <u>19.75</u><br>502                           |                                   |                                |          |
|          | 600        | <u>10.75</u><br>273 | <u>16.25</u><br>413        | <u>19.75</u><br>502                           |                                   |                                |          |
|          | 900        | <u>10.75</u><br>273 | <u>16.25</u><br>413        | <u>20.5</u><br>521                            |                                   |                                |          |
|          | 1500       | <u>12.38</u><br>314 | <u>17.88</u><br>454        | <u>22.75</u><br>578                           |                                   |                                |          |
| 4<br>100 | 150        | <u>14</u><br>356    | <u>21</u><br>533           | <u>24</u><br>610                              | 10<br>254                         | 1<br>25.4                      |          |
|          | 300        | <u>14</u><br>356    | <u>21</u><br>533           | <u>24.38</u><br>619                           |                                   |                                |          |
|          | 400        | <u>14</u><br>356    | <u>21</u><br>533           | <u>24.75</u><br>629                           |                                   |                                |          |
|          | 600        | <u>14</u><br>356    | <u>21</u><br>533           | <u>25.25</u><br>641                           |                                   |                                |          |
|          | 900        | <u>14.5</u><br>368  | <u>21.5</u><br>546         | <u>26.25</u><br>667                           |                                   |                                |          |
|          | 1500       | <u>15.5</u><br>394  | <u>22.5</u><br>571         | <u>27.63</u><br>702                           |                                   |                                |          |
| 6<br>150 | 150        | <u>16.5</u><br>419  | <u>24.5</u><br>622         | <u>28</u><br>711                              | 12<br>305                         | 1.5<br>38.1                    |          |
|          | 300        | <u>16.5</u><br>419  | <u>24.5</u><br>622         | <u>28.38</u><br>721                           |                                   |                                |          |
|          | 400        | <u>16.5</u><br>419  | <u>24.5</u><br>622         | <u>28.81</u><br>732                           |                                   |                                |          |
|          | 600        | <u>16.5</u><br>419  | <u>24.5</u><br>622         | <u>29.38</u><br>746                           |                                   |                                |          |
|          | 900        | <u>16.5</u><br>419  | <u>24.5</u><br>622         | <u>30.25</u><br>768                           |                                   |                                |          |
|          | 1500       | <u>19.25</u><br>489 | <u>27.25</u><br>692        | <u>34.25</u><br>870                           |                                   |                                |          |
| 8<br>200 | 150        | <u>20.25</u><br>514 | <u>29.38</u><br>746        | <u>33.38</u><br>848                           | 14<br>356                         | 2<br>50.8                      |          |
|          | 300        | <u>20.25</u><br>514 | <u>29.38</u><br>746        | <u>33.75</u><br>857                           |                                   |                                |          |
|          | 400        | <u>20.25</u><br>514 | <u>29.69</u><br>754        | <u>34.56</u><br>878                           |                                   |                                |          |
|          | 600        | <u>20.25</u><br>514 | <u>29.69</u><br>754        | <u>35.19</u><br>894                           |                                   |                                |          |
|          | 900        | <u>20.25</u><br>514 | <u>29.63</u><br>752        | <u>36.25</u><br>921                           |                                   |                                |          |
|          | 1500       | <u>23.25</u><br>591 | <u>33.38</u><br>848        | <u>42</u><br>1069                             |                                   |                                |          |

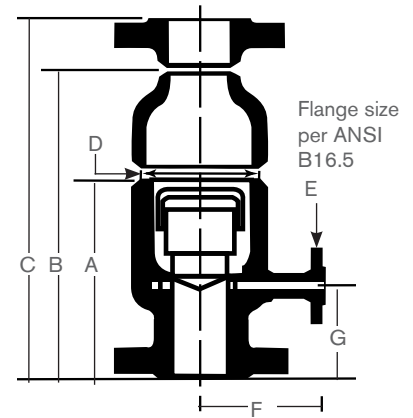

Typical Fabricated Arrangement

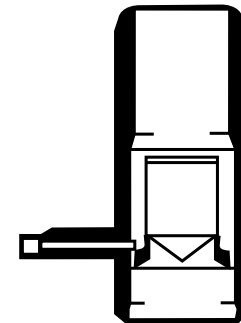

A VO-76 typically will be one nominal size smaller than the equivalent VO-II. Both will have the same size plug and internal components.

Request available pressure/temperature ratings and dimensions.

Note: All dimensions are subject to change without notice.

Request certified drawings.

Please contact Copes-Vulcan for F and G dimensions.

Inch  
Millimeter

# VO-76 Dimensions (Cont.)

ANSI Pressure Classes 150-1500

| Size      | ANSI Class | A<br>Housing  | B<br>Housing w/<br>Reducer | C<br>Housing w/<br>Reducer &<br>Outlet Flange | D<br>Housing &<br>Reducer<br>I.D. | E<br>Coolant<br>Flange<br>Size | F &<br>G |
|-----------|------------|---------------|----------------------------|---|-----------------------------------|--------------------------------|----------|
| 10<br>250 | 150        | 25.25<br>641  | 35.19<br>894               | 39.19<br>995                                  | 16<br>406                         | 2.5<br>63.5                    |          |
|           | 300        | 25.25<br>641  | 35.19<br>894               | 39.81<br>1011                                 |                                   |                                |          |
|           | 400        | 25.25<br>641  | 35.63<br>905               | 40.75<br>1035                                 |                                   |                                |          |
|           | 600        | 25.25<br>641  | 35.63<br>905               | 41.88<br>1064                                 |                                   |                                |          |
| 12<br>300 | 150        | 29.88<br>759  | 42.19<br>1071              | 46.75<br>1187                                 | 20<br>508                         | 3<br>76.2                      |          |
|           | 300        | 29.88<br>759  | 42.19<br>1071              | 47.38<br>1203                                 |                                   |                                |          |
|           | 400        | 29.88<br>759  | 42.69<br>1084              | 48.38<br>1229                                 |                                   |                                |          |
|           | 600        | 29.88<br>759  | 42.69<br>1084              | 49.13<br>1248                                 |                                   |                                |          |
| 14<br>350 | 150        | 34.13<br>867  | 47.81<br>1214              | 52.81<br>1341                                 | 24<br>610                         | 3<br>76.2                      |          |
|           | 300        | 34.13<br>867  | 47.81<br>1214              | 53.44<br>1357                                 |                                   |                                |          |
|           | 400        | 34.13<br>867  | 48.69<br>1237              | 55.56<br>1411                                 |                                   |                                |          |
|           | 600        | 34.13<br>867  | 49.44<br>1256              | 56.19<br>1427                                 |                                   |                                |          |
| 16<br>400 | 150        | 37.63<br>956  | 52.94<br>1344              | 57.94<br>1472                                 | 26<br>660                         | 3.5<br>88.9                    |          |
|           | 300        | 37.63<br>956  | 53.25<br>1352              | 59<br>1499                                    |                                   |                                |          |
|           | 400        | 37.63<br>956  | 53.5<br>1359               | 59.75<br>1518                                 |                                   |                                |          |
|           | 600        | 37.63<br>956  | 53.5<br>1359               | 60.75<br>1543                                 |                                   |                                |          |
|           | 900        | 38.13<br>968  | 55.25<br>1403              | 64<br>1626                                    |                                   | 4<br>101.6                     |          |
| 18<br>450 | 150        | 36.75<br>933  | 53.13<br>1349              | 58.63<br>1489                                 | 28<br>711                         | 4<br>101.6                     |          |
|           | 300        | 36.75<br>933  | 53.13<br>1349              | 59.38<br>1508                                 |                                   |                                |          |
|           | 400        | 36.75<br>933  | 53.75<br>1365              | 60.5<br>1537                                  |                                   |                                |          |
|           | 600        | 36.75<br>933  | 54.75<br>1391              | 62.25<br>1581                                 |                                   |                                |          |
| 20<br>500 | 150        | 38.13<br>968  | 54.63<br>1387              | 60.31<br>1532                                 | 30<br>762                         | 4<br>101.6                     |          |
|           | 300        | 38.13<br>968  | 55.38<br>1406              | 61.75<br>1568                                 |                                   |                                |          |
|           | 400        | 38.13<br>968  | 56.13<br>1425              | 63<br>1600                                    |                                   |                                |          |
|           | 600        | 38.13<br>968  | 54.69<br>1389              | 62.44<br>1586                                 |                                   |                                |          |
| 24<br>600 | 150        | 40.38<br>1026 | 59.88<br>1521              | 65.88<br>1673                                 | 36<br>914                         | 3<br>76.2                      |          |
|           | 300        | 41.63<br>1057 | 62.5<br>1587               | 69.13<br>1756                                 |                                   |                                |          |
|           | 400        | 43.5<br>1105  | 65<br>1651                 | 72.13<br>1832                                 |                                   |                                |          |
|           | 600        | 44.75<br>1137 | 66.25<br>1683              | 74.5<br>1892                                  |                                   |                                |          |

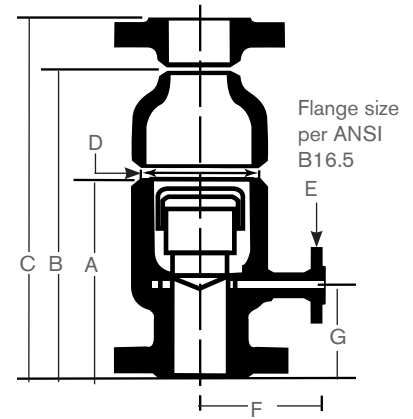

Typical Fabricated Arrangement

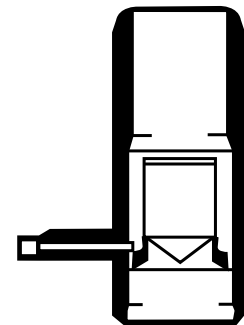

Please contact Copes-Vulcan for F and G dimensions.

A VO-76 typically will be one nominal size smaller than the equivalent VO-II. Both will have the same size plug and internal components.

Request available pressure/temperature ratings and dimensions.

Note: All dimensions are subject to change without notice.

Request certified drawings.

Inch  
Millimeter

|   |   |
|---|---|
|     | <h3 style="text-align: center;">SPECIAL APPLICATION GLOBE STYLE CONTROL VALVES</h3> <ul style="list-style-type: none"> <li>▪ General Service application</li> <li>▪ Severe Duty application</li> <li>▪ High turndown</li> <li>▪ .75 - 24" Sizes</li> <li>▪ 150 - 4500 ANSI Ratings</li> <li>▪ Special ANSI Ratings</li> <li>▪ Meets ASTM/ASME Standards</li> <li>▪ Threaded, Butt/Socket Weld, Flanged Ends</li> </ul>  |
|    | <h3 style="text-align: center;">STEAM CONDITIONING EQUIPMENT (DESUPERHEATERS)</h3> <ul style="list-style-type: none"> <li>▪ 7 Styles</li> <li>▪ Mechanical Atomizing</li> <li>▪ Variable Orifice</li> <li>▪ Integral Cooling Water function available</li> <li>▪ High turndowns</li> <li>▪ 150 - 2500 ANSI Ratings</li> <li>▪ Special ANSI Ratings</li> <li>▪ Meets ASTM/ASME Standards</li> </ul>  |
|    | <h3 style="text-align: center;">TRIM TYPES</h3> <ul style="list-style-type: none"> <li>▪ 13 types</li> <li>▪ RAVEN™</li> <li>▪ HUSH™</li> <li>▪ CAV B9©</li> <li>▪ One Stage Hush©</li> <li>▪ Noise control</li> <li>▪ Cavitation elimination</li> <li>▪ Velocity &amp; Erosion control</li> </ul>  |
|    | <h3 style="text-align: center;">ACTUATORS</h3> <ul style="list-style-type: none"> <li>▪ Diaphragm Style. Model 700</li> <li>▪ Diaphragm Style. Model 1000</li> <li>▪ Manual Style 820</li> <li>▪ Electric available</li> <li>▪ Electro/Hydraulic available</li> <li>▪ Piston</li> <li>▪ Reverse acting</li> <li>▪ Direct acting</li> </ul>  |
|    | <h3 style="text-align: center;">NUCLEAR CONTROL VALVES</h3> <ul style="list-style-type: none"> <li>▪ Pneumatic, Motor, Manual Operators</li> <li>▪ Metal &amp; Resilient Seats</li> <li>▪ Widest Selection of Trim in the Industry</li> <li>▪ Size Range: 3/8" - 20" class 150 - 2500</li> <li>▪ Globe, Angle, Isolation &amp; Three Way Body Configurations</li> <li>▪ ASME Section III "N" &amp; "NPT" Stamp Certified</li> </ul>   |
|   | <h3 style="text-align: center;">NUCLEAR HIGH PERFORMANCE BUTTERFLY AND BALL VALVES</h3> <ul style="list-style-type: none"> <li>▪ Bi-Directional Class VI Shut off</li> <li>▪ Metal &amp; Resilient Seats</li> <li>▪ Pneumatic, Motor, Manual Operators</li> <li>▪ Modulating or Isolation</li> <li>▪ Two &amp; Three Piece Ball Valve design</li> <li>▪ Torque Seated/Position Seated (Butterfly only)</li> <li>▪ ASME Section III "N" &amp; "NPT" Stamp Certified</li> </ul> |
|  | <h3 style="text-align: center;">AFTERMARKETS AND REFURBISHMENTS</h3> <ul style="list-style-type: none"> <li>▪ Reduce Outage Cycle Times</li> <li>▪ Maximize Years/Life Cycle</li> <li>▪ Recondition the OEM parts, while minimizing lead times and costs.</li> </ul>  |

Common Applications: Power, Pulp & Paper, Water, Oil & Gas, Petrochemical.  
 Manufacturing Standards: Certifications - ISO-9001, ASME SECTION III "N" & "NPT" Stamps, ASME SECTION I "S" Stamp, CSA-Z299.2, .3 & .4, 97/23/EC-PED-CE



**FLOW CONTROL**



SPX Flow Control  
 5620 West Rd.  
 McKean, PA 16426  
 Phone: (814)476-5800 Fax: (814)476-5854  
 E-mail: cv@spx.com

For more information about our worldwide locations, approvals, certifications, and local representatives, please visit [www.spxfc.com](http://www.spxfc.com).  
 SPX reserves the right to incorporate our latest design and material changes without notice or obligation.  
 Design features, materials of construction and dimensional data, as described in this bulletin, are provided for your information only and should not be relied upon unless confirmed in writing. Certified drawings are available upon request.